



COMPACT FOOT SWITCH

LINEMASTER® is pleased to bring to you the very versatile Compact foot switch. This switch is ideal if you are looking for a robust foot switch solution in a small package. Used in many different fields, the Compact is used most commonly in emergency vehicles and with tattoo equipment. Its small size allows the user to easily maneuver the foot switch around the floor. The quality design, along with the steel structure of the Compact foot switch make it a popular choice for the people looking for a switch that they can rely on. Available in single & multi-pedal versions to fit most applications. Only from LINEMASTER® - American made innovation at work.

LIT-042 Rev. C



LINEMASTER Switch Corporation
Tel (860) 974-1000

29 Plaine Hill Rd, P.O. Box 238
Woodstock, Connecticut 06281-0238 USA
Fax (800) 974-FOOT(3668)

www.linemaster.com

COMPACT FOOT SWITCH

FEATURES

- Steel housing painted black
- Metal mounting plate spot welded to the base on the 491-SC36MP model
- Twin baseplate formed from cast aluminum
- The twin model is supplied with a divider bar between the pedals which helps prevent accidental operation of both pedals at one time
- Non-skid basepad for secure placement
- Compact in size and light in weight
- 2 mounting holes for rigid mounting to floor or equipment
- Heavy gauge steel guards available
- Airval models available upon request



SINGLE

SIZE (HxWxD): 1.28 x 2.50 x 2.87 In.

WEIGHT: 7.00 oz



TWIN

SIZE (HxWxD): 1.46 x 5.98 x 2.875 In.

WEIGHT: 1.25 lbs.



MOUNTING BRACKET MODEL

SIZE (HxWxD): 1.28 x 3.50 x 2.87 In.

WEIGHT: 1.05 lbs.

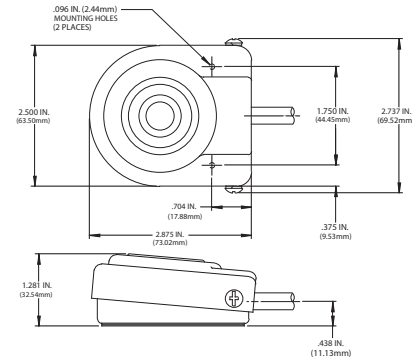
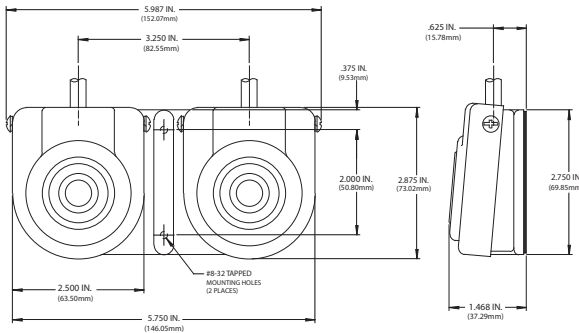

AGENCY APPROVALS	EN 60529 DEGREE OF PROTECTION	CATALOG NUMBER	DESCRIPTION	CIRCUIT	FORM	ELECTRICAL RATINGS
	IP20	491-S	Single / Momentary	SPDT	C	10 A 125-250 VAC 1/2 H.P. 125-250 VAC
	IP20	491-SC36 ¹	Single / Momentary	SPDT Wired N.O.	A	10 A 125 VAC 1/2 H.P. 125-250 VAC
	IP20	491-SC3 ²	Single / Momentary	SPDT Wired N.O.	A	10 A 125 VAC 1/2 H.P. 125-250 VAC
	IP20	492-S	Single / Momentary	SPDT	C	20 A 125-250 VAC 1 H.P. 125-250 VAC
	IP20	TWIN 491-S	Twin / Momentary	SPDT - Each Side	C	10 A 125-250 VAC 1/2 H.P. 125-250 VAC
	IP20	491-SC36MP ¹	Single / Momentary with Mounting Plate	SPDT Wired N.O.	A	10 A 125-250 VAC 1/2 H.P. 125-250 VAC

¹ Supplied with 8 ft. 16/3 cord without plug. Green lead grounded. ² Supplied with 6 ft. 16/3 cord with 3 prong series plug. Green lead grounded.