

DELUXE II FOOT SWITCH

LINEMASTER® is pleased to present the very durable and sleek Deluxe II foot switch series. The Deluxe II foot switch was designed to offer the end user a multi-pedal solution in a small foot print. The robust polymeric cover and die cast metal treadle & base make up a quality foot switch with a long life. Used in many different applications, the Deluxe II can most commonly be seen on communication equipment, medical chairs & tables, and calibration test equipment. As an added feature the Deluxe II can be supplied with a vinyl cover for added protection against a number of different foreign substances. Only from LINEMASTER® - American made innovation at work.

LIT-041 Rev. C



LINEMASTER Switch Corporation
Tel (860) 974-1000

29 Plaine Hill Rd, P.O. Box 238
Woodstock, Connecticut 06281-0238 USA
Fax (800) 974-FOOT(3668)

www.linemaster.com

DELUXE II FOOT SWITCH

FEATURES

- Cover is molded from medium gray high impact polymeric material
- Base and treadles are made of die cast metal
- The cover tapers close to the floor in the front with a full five inches between the side treadle bars
- A non-skid base pad provides a secure placement
- The switch incorporates a unique building block approach that allows the use of up to four basic SPDT snap switches
- Supplied with internal adjustable strain relief for cord
- Special variations are available upon request. Special variations include: custom cables, nameplates, two stage operation, non-operative cover, special circuits, and special translucent molded vinyl cover for added environmental protection against limited amounts of water and dirt
- The translucent vinyl cover is made by a dip molding process. Minor cosmetic imperfections and blemishes are inherent in dip molded parts and must be expected. The basic environmental protection is not affected

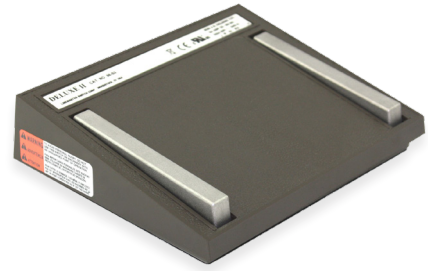

MULTI PEDAL

SIZE (HxWxD): 1.67 x 6.87 x 5.64 In.

WEIGHT: 2.00 lbs.

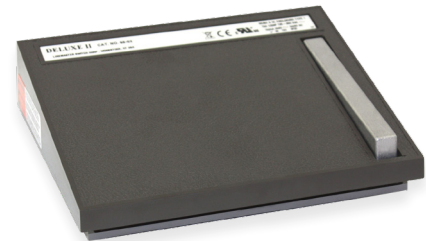

SINGLE

SIZE (HxWxD): 1.67 x 6.87 x 5.64 In.

WEIGHT: 2.00 lbs.

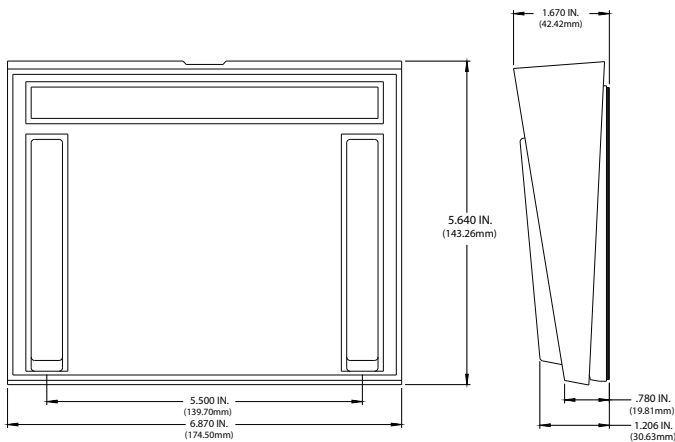

APPROVALS	EN 60529 Degree of Protection	CATALOG NUMBER	DESCRIPTION	PEDALS	CIRCUIT	FORM	ELECTRICAL RATINGS
	IP20	68-S3	Dual Treadle / Momentary	2 Pedals plus Cover	SPDT	C	10 A 125-250 VAC 1/2 H.P. 125-250 VAC
	IP20	68-S3N	Dual Treadle / Momentary	2 Pedals ¹	SPDT	C	
	IP20	68-S4N	Dual Treadle / Momentary	2 Pedals ¹	DPDT	C	
	IP20	68-S2	Single Treadle / Momentary	1 Pedal plus Cover	SPDT	C	

¹ Cover non-operative with side treadle bars active.