



DUPLEX FOOT SWITCH

LINEMASTER's Duplex foot switch operates as a heel-toe rocker switch allowing the user to operate 2 functions with a single foot pedal look. At rest the pedal is in the off position, but pressing down with your heel or toe will activate a function. The Duplex accommodates a wide range of cable sizes and offers an EN 60529 Degree of Protection IP20. Do you have special requirements? Please contact Linemaster for a quotation for a custom variation built to your specifications, including cordset, paint finish, and labeling.

LIT-046 Rev. C



LINEMASTER Switch Corporation
Tel (860) 974-1000

29 Plaine Hill Rd, P.O. Box 238
Woodstock, Connecticut 06281-0238 USA
Fax (800) 974-FOOT(3668)

www.linemaster.com

DUPLIX FOOT SWITCH

FEATURES

- Die cast aluminum housing
- Mechanical Interlock-prevents both circuits from being operated at the same time
- Operates on Teeter-Totter Principle
- Non-skid base pad
- Eliminates costly harness assemblies
- Housing is pivoted in the center for easy heel-toe operation
- EN 60529 Degree of Protection IP20
- Both wires can be wired normally open or normally closed



SINGLE

SIZE (H x W x D): 2.09 x 3.50 x 8.31 In.

WEIGHT: 1.75 lbs.

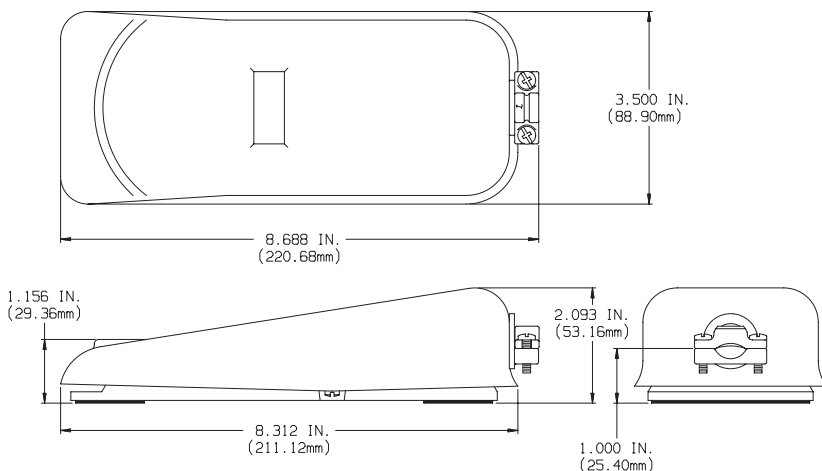

AGENCY APPROVALS	EN 60529 DEGREE OF PROTECTION	CATALOG NO.	DESCRIPTION	CIRCUIT	FORM	ELECTRICAL RATING
N/A	IP20	476-S	Momentary	SPDT Each Side	C	15 A 125-250 VAC 1/2 H.P. 125-250 VAC